

# VIMARI 2316 - Hand-operated

## FIXING THE SOCKET IN THE PAVEMENT

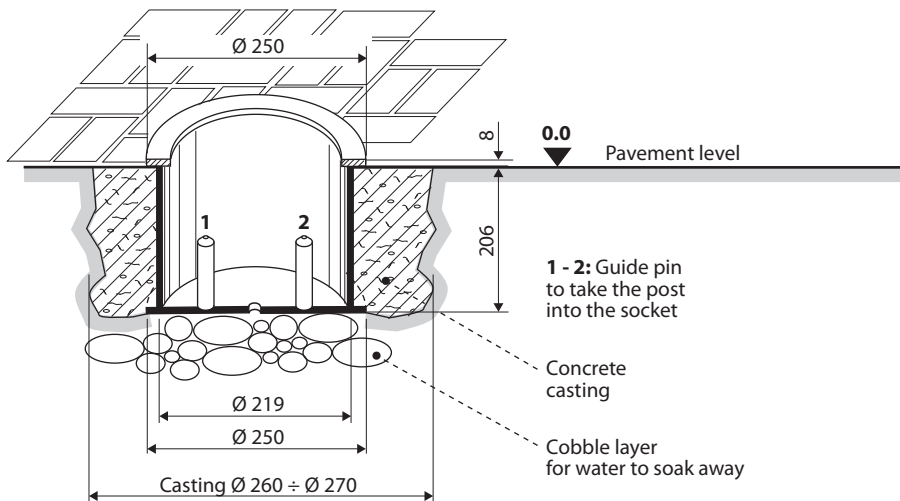

## RELEASING OPERATIONS AND REMOVAL OF THE POST

### Removal of the post:

- Insert the specially shaped spanner into the lock under the post cover.
- To **release** and remove the post, turn the spanner **clockwise** and lift the post out of the socket.
- Let the post stand and **remove the spanner** by turning it **anti-clockwise**.
- Cover the socket by means of the **lid** provided with the equipment.

### Setting the post back:

carry out the previous operations in the back sequence: insert the spanner, turn it **clockwise** and put the post back into the socket, then **lock it** in position and **remove the spanner** by turning it **anti-clockwise**.

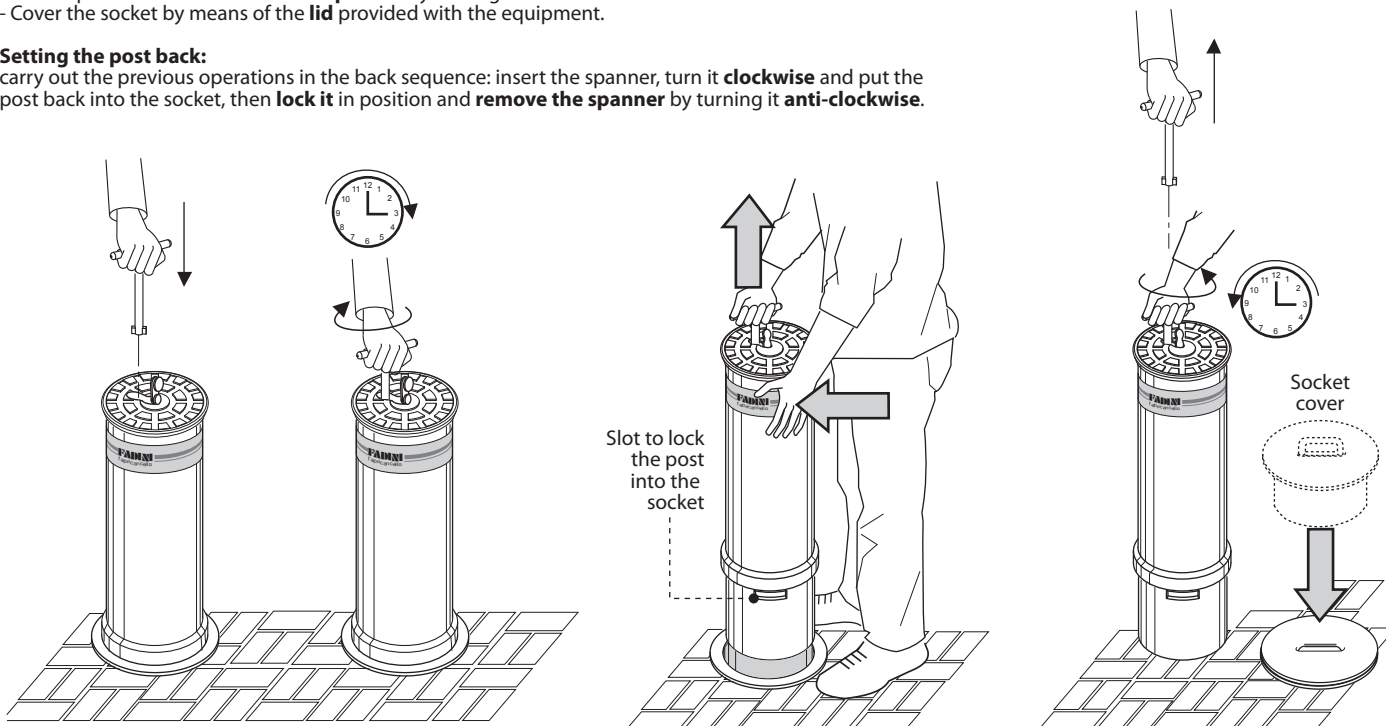

## OVERALL DIMENSIONS

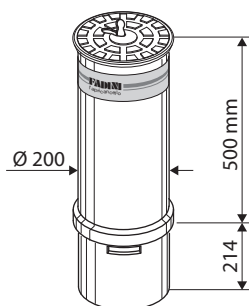

Post

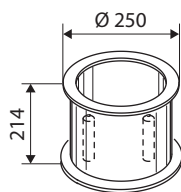

Socket

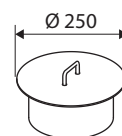

Socket cover

Post diameter (mm)	Post height (mm)	Post thickness (mm)	Post finish
200	500	4	RAL 7016 Anthracite Grey

GB

Drw. N. 4896

INSTRUCTIONS FOR THE INSTALLATION AND REMOVAL OF **VIMARI 2316** REMOVABLE MANUAL POST

meccanica **FADINI**